

» Application Story «

ThinkIO in Transportation



Image processing in the fast lane: tire tread check at 120 km/h

Kontron ThinkIO-Duo DIN Rail PC with multicore performance delivers high-speed image processing for innovative traffic safety systems



ProContour, a company based in South Germany, has developed the H3-D, a new multi-functional image processing system which opens up completely new perspectives for road safety.

It can measure tire tread patterns contact-free in moving traffic - reproducible even at speeds of up to 120 km/h. The computing required for this high-speed image capturing is carried out by the Kontron's DIN rail ThinkIO-Duo. The winning features of the system are the multi-core computing performance and its robust and silent design plus a wide range of interface options, with which the image processing system can be integrated into other applications.

Worldwide, poor tire treads are one of the most common technical reasons for traffic accidents: In wet and slippery road conditions, tires with low tread depth lose their grip on the road surface. That can result in extended braking distances. The danger of aquaplaning is also increased, the vehicle skims over the surface and goes out of control. Spot-checking of the depth of tire tread is only however carried out by the police at irregular intervals. Dynamic measurement of tire tread depth could bring about a radical change: In flowing traffic, 100 percent of all vehicles, trucks, buses and cars could be controlled. The measuring system ProContour H3-D is such a system. It is available in several different versions. Applications have already been submitted to the Physical-Technical Institute (PTB) (national metrology institute providing scientific and technical services), for technical approval of a design which achieves results which can be used in court as evidence. Critical stretches of roads could be subject to nearly 100% supervision for increased road safety. The system automatically measures tread depth and tread type and can provide the information via Ethernet cable or wireless LAN in order to control warning systems, barriers, camera systems or even road blockages.



Image 1: The image processing system ProContour H3-D measures tire tread depths at up to 120 km/h in moving traffic

The principle of laser triangulation

The traffic safety system ProContour H3-D measures tire tread depth without any influence on flowing traffic. In order to achieve this, 4 measuring heads are embedded in shafts or ducts in the road. Every measuring module covers a breadth of approx. 380 mm to 670 mm. Depending on the size, the modules have one or two laser diodes, a laser beam controller and CMOS sensor-controlled digital cameras with GigE vision interface. The ThinkIO-Duo is another integral part of the system which – due to its compact dimensions – can be fitted into the system taking up very little space.

The measuring method of the ProContour H3-D is based on the principle of laser triangulation. The laser diodes which cause no harm to the human eye projects a light beam onto the tire surface. The direction of the beam and the distance between the camera and the tire are known factors, and from the image which is taken, trigonometric data can be calculated for tread depth measurement.

Real time capability is what counts

A fast CMOS sensor detects a vehicle on the measuring head. The lasers oscillate the measuring pattern for 2.4 milliseconds over the contact area of the tire. During this time the camera captures several images with a maximal frequency of up to 16,000 images a second. This high resolution image data (1536 x 512 pixel) is transferred via two interrupt-capable Gigabit-Ethernet interfaces to the ThinkIO-Duo. With its high computing performance the ThinkIO-Duo is in a position to process the image data in real time. The camera images on both cores are simultaneously processed in symmetrical multi-processing. In just a little more than two milliseconds – actually even faster than the capture process – the ThinkIO-Duo calculates whether the measured tire has the required tread depth. Any interferences caused by objects in the tire tread are recognized and filtered out. Parallel processing which has only now become affordable due to multi-core systems brings the computing speed of the image processing system up to a level that is necessary for the real time calculation of laser-detected surface characteristics of a vehicle's tire at 120 km/h driving speed. The ProContour H3-D is a very impressive example of multi-core based image processing applications. First tests on highways, for example between the South German towns of Waldshut and Tiengen on the B34 already confirm that the image processing system ProContour H3-D is ready to market.

To ensure that the traffic safety system can be used by municipal authorities, the data must be tamper-proof in order to be used as evidence in court. For this reason the whole measuring head including the ThinkIO-Duo is sealed. It is a further essential feature that all the software is open source in order to guarantee investment security. The platform which was evaluated under Windows XP is now being migrated to Linux. After this the system will be submitted to the German PTB (Physikalisch Technische Bundesanstalt) for certification.

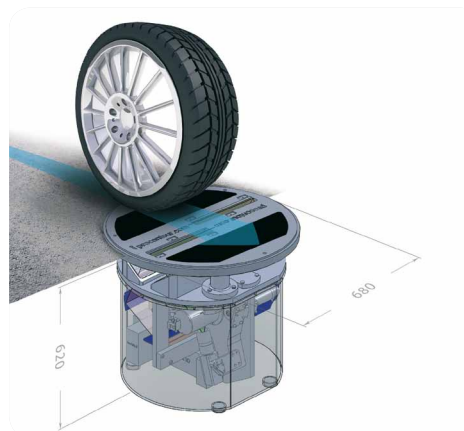

Image 2: Via laser diode-digital cameras, which are fit into shafts in the highway or troughs, tire treads depths can be captured and calculated in milliseconds by the integrated DIN rail PC, Kontron ThinkIO.

Flexible fields of application

The ProContour H3-D has an enormous potential of application areas. That is why the applied system should not only be fast but ideally also be expandable and versatile. In this way it is conceivable that the ProContour measuring module can be connected to other existing traffic safety equipment and measuring systems. For example, the combination of display panels, traffic lights, barrier systems, toll gates or weighing stations for trucks would make sense. The connection to control centres is imaginable. Many applications can be integrated simply and inexpensively via the large range of the ThinkIO-Duo's standard interfaces. If the standard set of features of the compact system does not suffice, extension via the optional modular Wago IO system is possible.

"The ThinkIO-Duo offers optimal characteristics for our H3-D measuring method: it is small, robust and delivers multi-core performance for high-speed image processing", explains Dipl.-Ing. Manfred Weber, development engineer at ProContour GmbH. "Due to the fact that we could integrate the ThinkIO-Duo in our measuring heads, it has increased the mobility of the system and its tamper-proof qualities for data security."



Image 3: The Kontron ThinkIO-Duo offers an extensive range of interfaces, from the standard PC to industrial fieldbus and Ethernet interfaces in an ultra-compact unit, which can be optionally extended with the optional modular Wago IO system.

A system with a future

Besides the application for measuring tire tread depths, the measuring system ProContour H3-D is also suitable for further application areas, in which rapid recognition of surface structures is required. Kontron's own RT-Linux distribution is also an interesting factor for ProContour. The distribution contains real time Linux driver packages of the Open Source Automation Development Labs (OSADL). ProContour doesn't have to think a lot about a real time configuration which matches the system.

AUTHOR



Ingrid Einsiedler,
Marketing Manager Transportation
at Kontron

About Kontron

Kontron designs and manufactures embedded and communications standards-based, rugged COTS and custom solutions for OEMs, systems integrators, and application providers in a variety of markets.

Kontron engineering and manufacturing facilities, located throughout Europe, North America, and Asia-Pacific, work together with streamlined global sales and support services to help customers reduce their time-to-market and gain a competitive advantage. Kontron's diverse product portfolio includes: boards & mezzanines, Computer-on-Modules, HMIs & displays, systems & platforms, and rugged & custom capabilities.

Kontron is a Premier member of the Intel® Embedded Alliance and has been a VDC Platinum Vendor for Embedded Computer Boards 5 years running.

Kontron is listed on the German TecDAX stock exchange under the symbol "KBC". For more information, please visit: www.kontron.com

CORPORATE OFFICES

Europe, Middle East & Africa

Oskar-von-Miller-Str. 1
85386 Eching/Munich
Germany

Tel.: +49 (0)8165/ 77 777
Fax: +49 (0)8165/ 77 279
info@kontron.com

North America

14118 Stowe Drive
Poway, CA 92064-7147
USA

Tel.: +1 888 294 4558
Fax: +1 858 677 0898
info@us.kontron.com

Asia Pacific

17 Building,Block #1,ABP.
188 Southern West 4th Ring Road
Beijing 100070, P.R.China

Tel.: + 86 10 63751188
Fax: + 86 10 83682438
info@kontron.cn

